



General Certificate of Secondary Education  
2024

Centre Number

--	--	--	--	--

Candidate Number

--	--	--	--

---

## Biology

Unit 2

Higher Tier

<b>MV24</b>
-------------

[GBL22]

TUESDAY 11 JUNE, MORNING

---

### Time

1 hour 30 minutes, plus your additional time allowance.

### Instructions to Candidates

Write your Centre Number and Candidate Number in the spaces provided at the top of this page.

**You must answer the questions in the spaces provided.**

**Do not write on blank pages.**

Complete in black ink only.

Answer **all ten** questions.

## Information for Candidates

The total mark for this paper is 90.

Figures in brackets printed at the end of each question indicate the marks awarded to each question or part question.

Quality of written communication will be assessed in Question **8(b)**.

1 (a) Explain how a plant loses water by transpiration. [3 marks]

---

---

---

---

---

---

---

**(b)** The graph opposite shows the mass of water lost by a plant kept in windy conditions for six hours.

**(i)** Calculate the rate of water loss per hour over six hours. [3 marks]

Give your answer **to one decimal place**.

Show your working.

\_\_\_\_\_ g per hour

**(ii) Draw a curve on the graph** showing the water loss for the same plant in humid conditions. [1 mark]

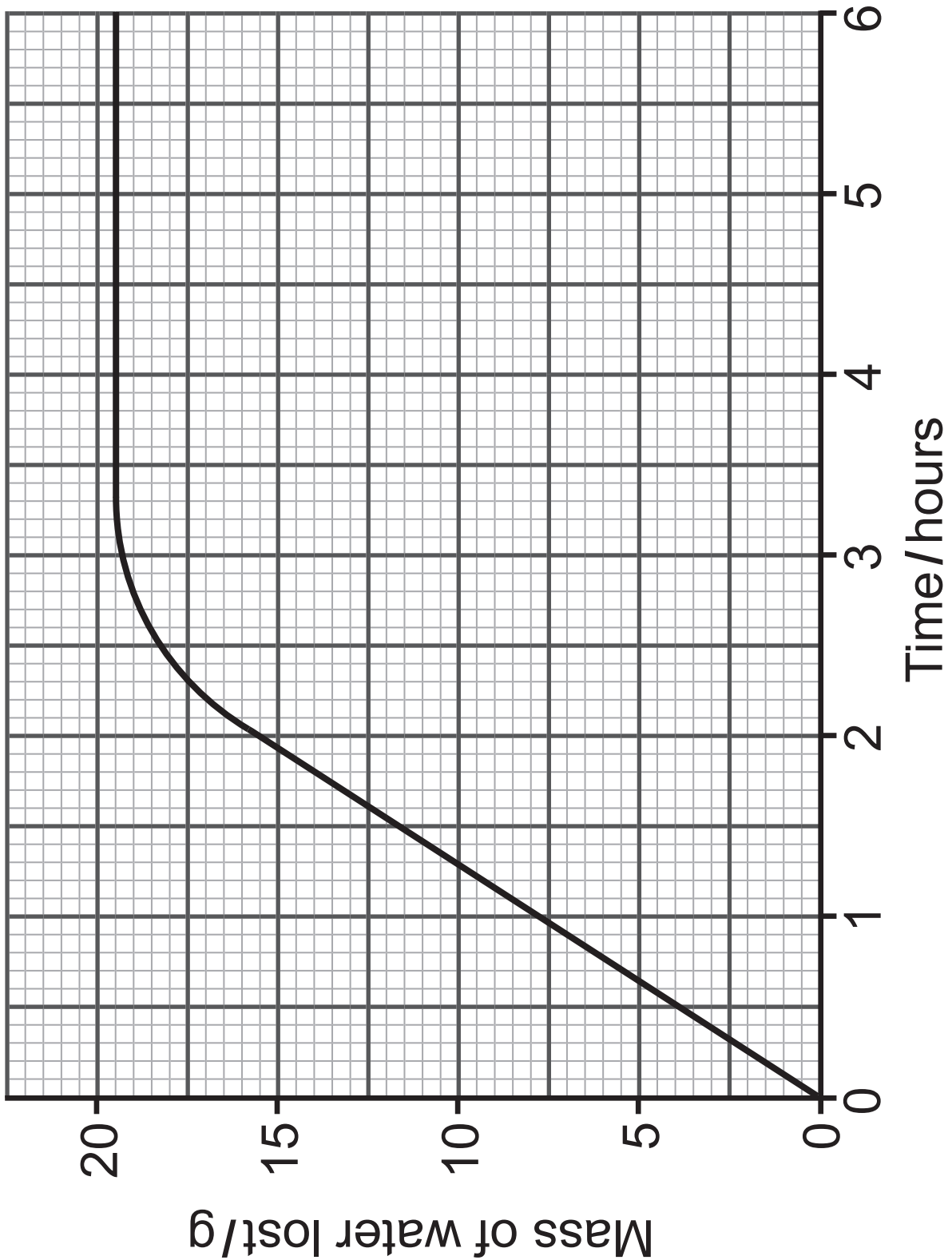

Transpiration is one way a plant uses water.

**(c)** Give **two other** ways a plant uses water.

[2 marks]

1. \_\_\_\_\_

2. \_\_\_\_\_

2 (a) The diagram shows a section through an artery of a patient who has had a stroke.

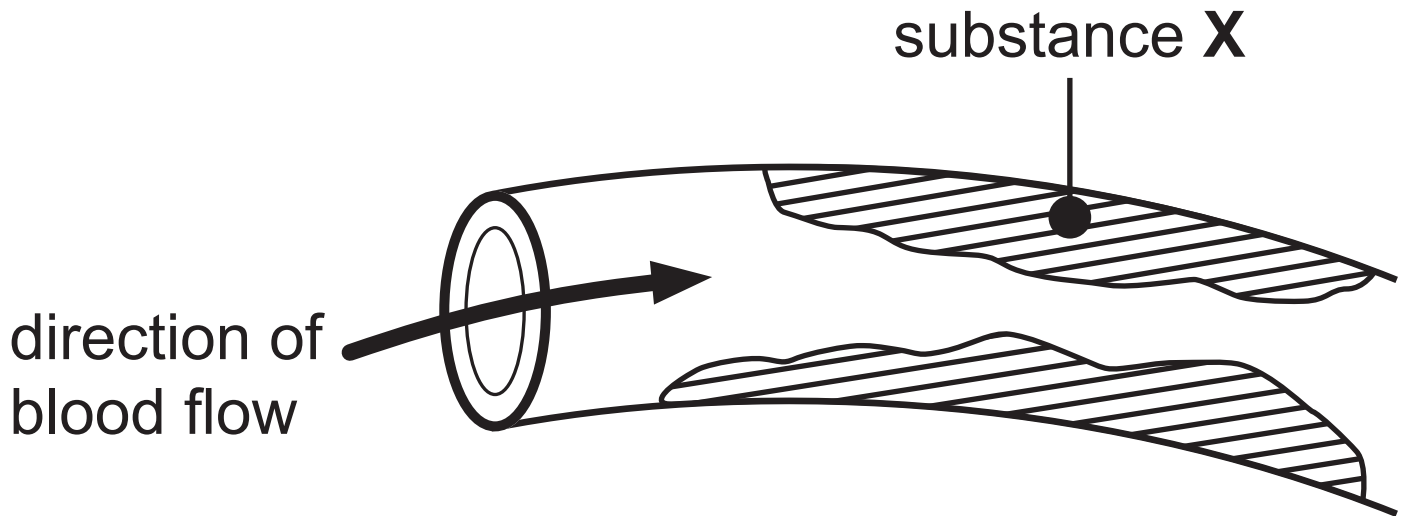

(i) Name substance X. [1 mark]

\_\_\_\_\_

(ii) Describe and explain why this patient may have another stroke if he does not receive treatment. [4 marks]

\_\_\_\_\_  
\_\_\_\_\_  
\_\_\_\_\_  
\_\_\_\_\_  
\_\_\_\_\_  
\_\_\_\_\_  
\_\_\_\_\_  
\_\_\_\_\_

The diagrams show three stages in the treatment received by the patient to reduce the chances of having another stroke.

In stage 1, a wire cage containing a balloon is pushed into the artery.

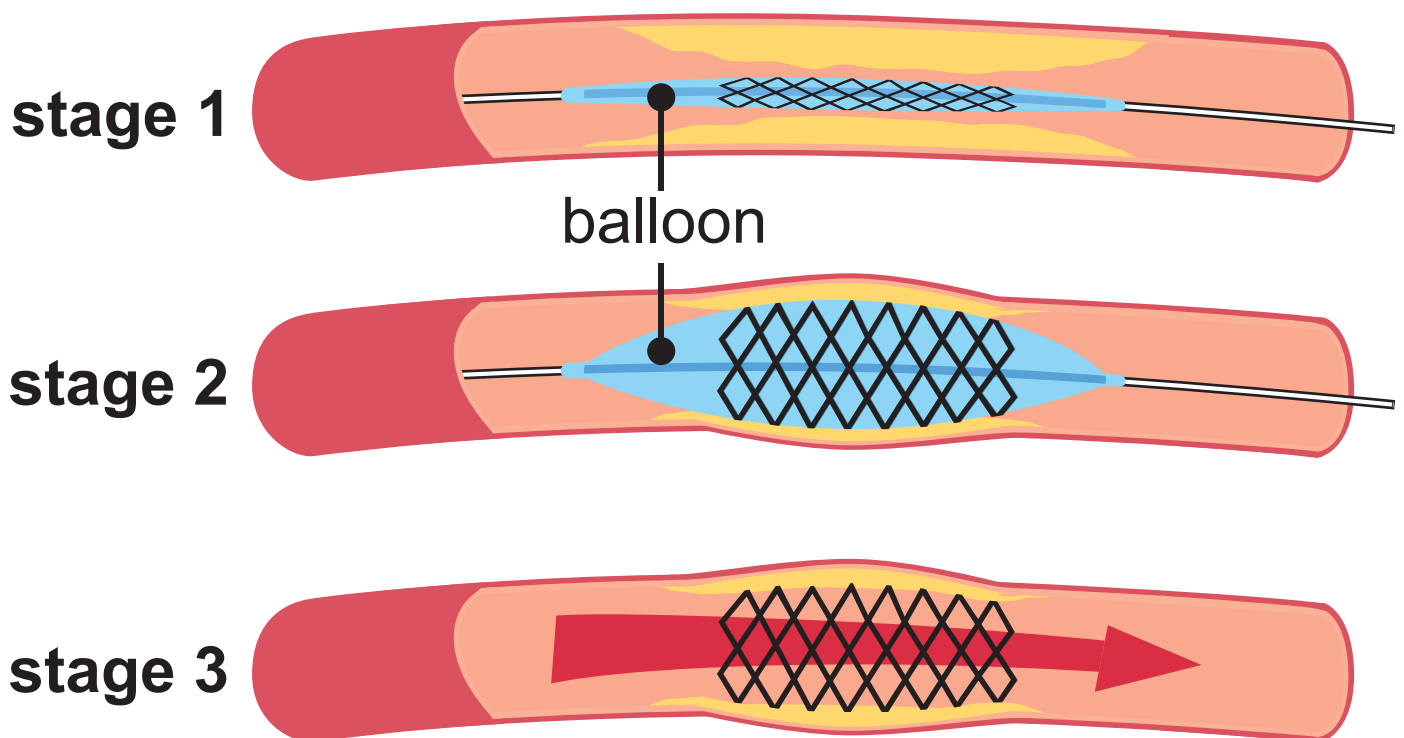

**(b)** Use the diagrams opposite to describe what happens in **stage 2** and **stage 3**.  
[4 marks]

Stage 2 \_\_\_\_\_

---

---

---

Stage 3 \_\_\_\_\_

---

---

---

**3 (a)** The diagrams show a cross section of an artery and a cross section of a vein.

**artery**

**vein**

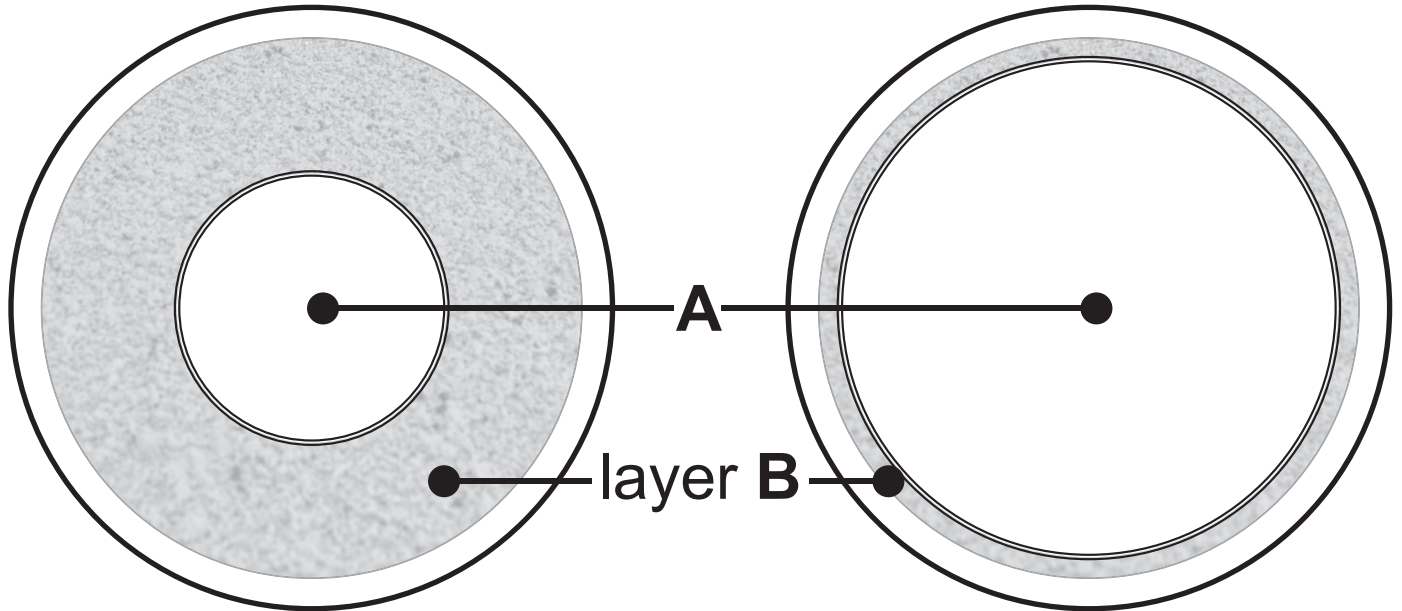

**(i)** Name part **A**. [1 mark]

---

(ii) Use the diagram opposite to describe how layer **B** in an artery is different from layer **B** in a vein.

Explain how this difference adapts the artery to its function. [3 marks]

Description \_\_\_\_\_

\_\_\_\_\_

\_\_\_\_\_

Explanation \_\_\_\_\_

\_\_\_\_\_

\_\_\_\_\_

\_\_\_\_\_

**(b)** The diagram shows a different section through a vein.

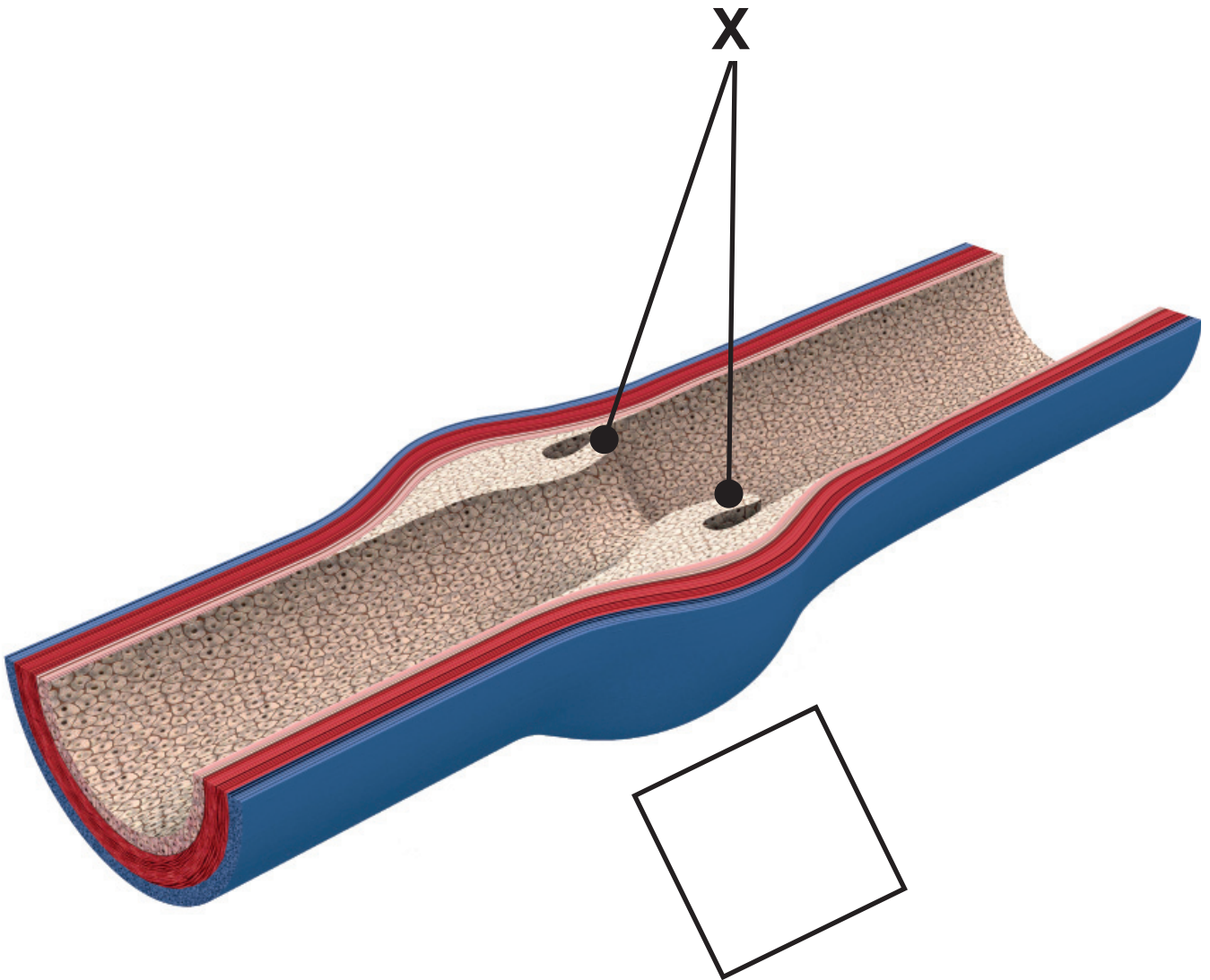

**(i)** Name structure **X** and explain its function. [2 marks]

Structure **X** \_\_\_\_\_

Function \_\_\_\_\_

\_\_\_\_\_  
\_\_\_\_\_

**(ii)** Draw an arrow **in the box** on the diagram opposite to show the direction of blood flow in this vein.  
[1 mark]

4 Diagram A shows the structure of part of the placenta.

## Diagram A

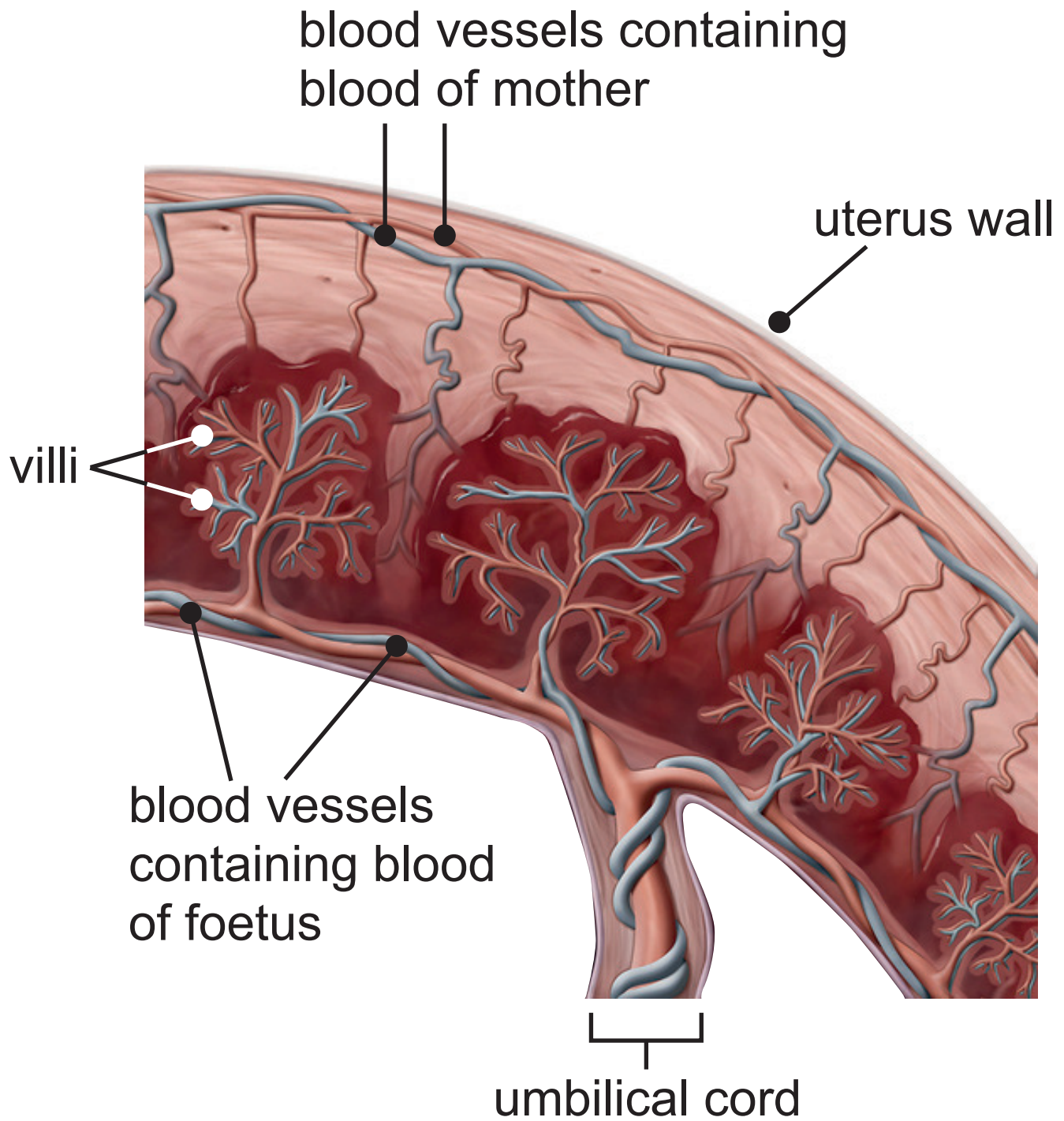

**(a)** Use evidence from the diagram opposite to describe and explain **two** ways villi adapt the placenta for the exchange of gases and nutrients. [4 marks]

Description \_\_\_\_\_

Explanation \_\_\_\_\_

Description \_\_\_\_\_

Explanation \_\_\_\_\_

**(b)** Diagram B shows a rare condition called a placental abruption.

In a placental abruption, part of the placenta separates from the uterus wall.

## Diagram B

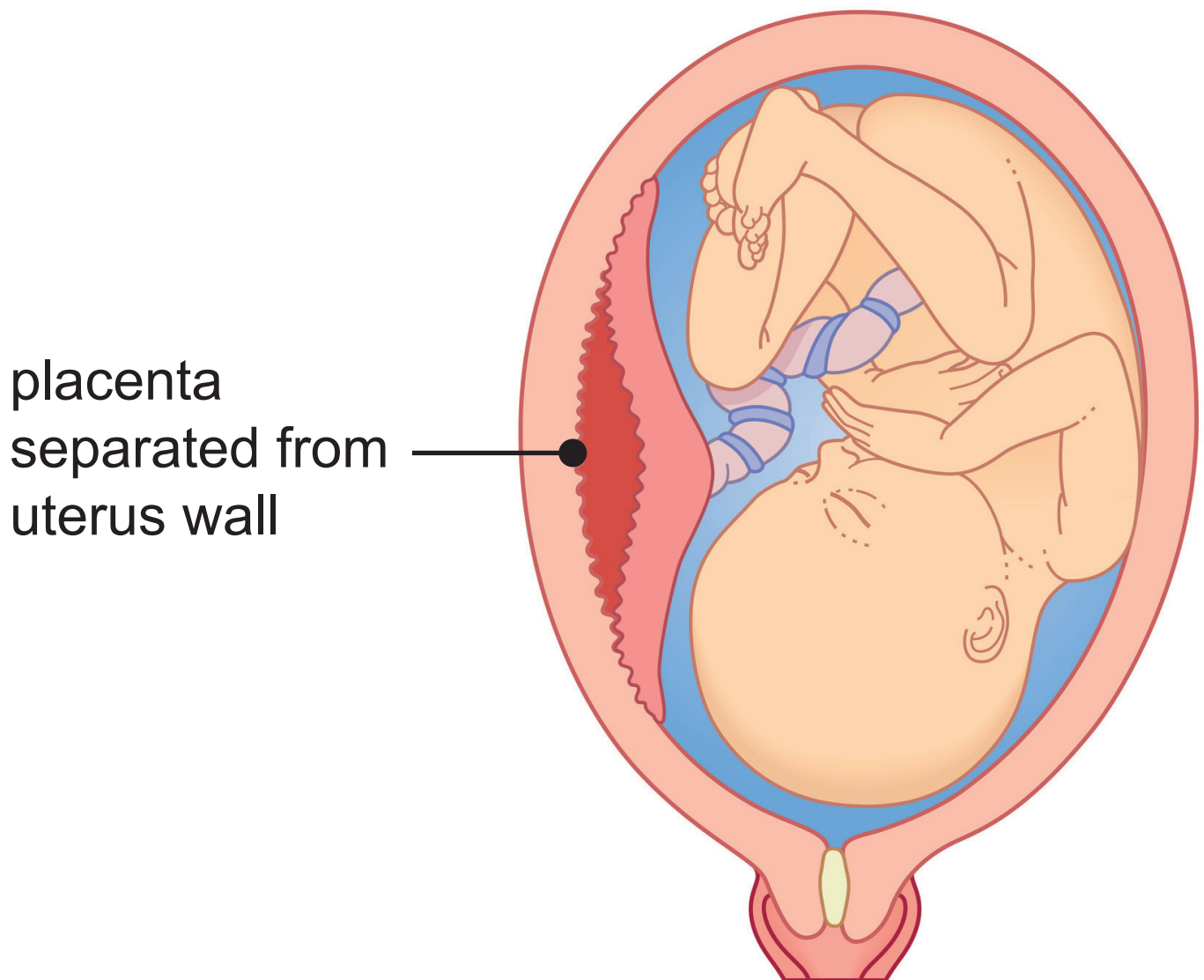

(i) Suggest what effect a placental abruption may have on the delivery of a **named** nutrient to a foetus.

[2 marks]

---

---

---

(ii) Describe how this may affect the growth of the foetus. [1 mark]

---

---

- 5 The diagram shows a population of bacteria and what happened when it was treated with an antibiotic.

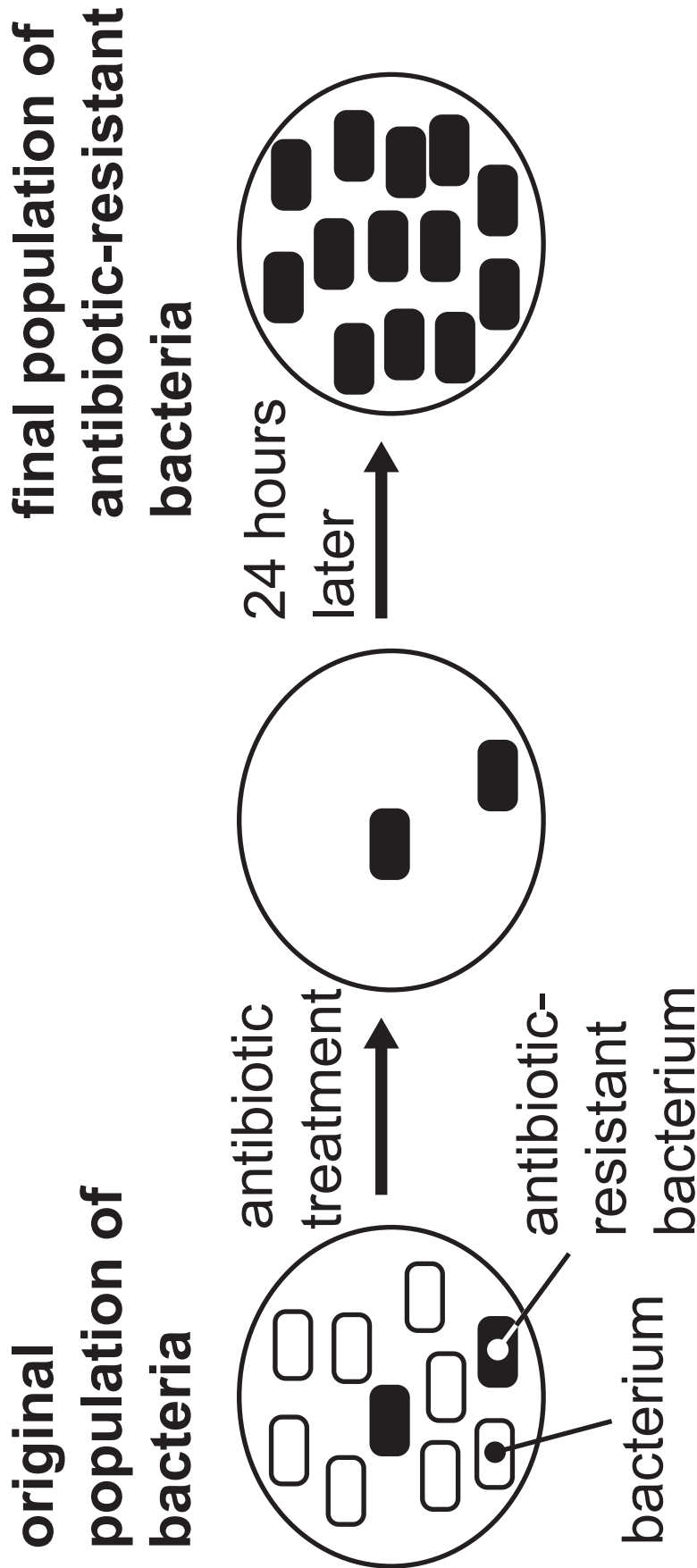

The original population of bacteria shows genetic variation.

This is caused by a random change in the DNA of the bacteria.

**(a)** What term describes this random change in the DNA of the bacteria? [1 mark]

---

**(b)** Explain how the antibiotic treatment results in the final population of antibiotic-resistant bacteria. [4 marks]

---

---

---

---

---

---

---

---

---

**(c)** Suggest how this population of antibiotic-resistant bacteria could develop into a superbug. [2 marks]

---

---

---

---

6 (a) COVID-19 is a disease which can be spread from one person to another.

(i) What term describes a disease which can be spread from one person to another? [1 mark]

---

COVID-19 is caused by a type of coronavirus which causes respiratory infections.

It spreads in a **similar way** to tuberculosis (TB).

(ii) Describe how COVID-19 can be **spread** from one person to another. [3 marks]

---

---

---

---

---

---

---

**(b)** The table shows the total number of COVID-19 cases reported in the UK from 15th February to 19th May in 2020.

<b>Date</b>	<b>Number of COVID-19 cases reported</b>
15th February	9
27th February	16
6th March	151
24th March	7 310
11th April	71 428
22nd April	120 706
7th May	186 909
19th May	224 980

- (i) Use the table opposite to calculate the percentage increase in the number of COVID-19 cases from 22nd April to 19th May. [3 marks]

Give your answer to **two decimal places**.

Show your working.

\_\_\_\_\_ %

- (ii) Suggest **one economic** impact on society of this increase in the number of COVID-19 cases. [1 mark]

---

---

**(c)** In Europe, the first clinical trials of a COVID-19 vaccine began on 23rd April 2020.

Before clinical trials begin, preclinical trials have to be carried out on tissues and animals.

**(i)** Give **two** reasons for carrying out preclinical trials. [2 marks]

1. \_\_\_\_\_

\_\_\_\_\_

2. \_\_\_\_\_

\_\_\_\_\_

Clinical trials of a vaccine are carried out on a small number of healthy volunteers before the vaccine is given to patients.

**(ii)** Explain the purpose of these clinical trials. [1 mark]

---

---

## 7 Some people have an allergic reaction to cats.

These allergic reactions are caused by proteins, called Fd proteins, found in the cat's fur.

The allergic reactions may include a runny nose, rash and itchy eyes.



**(a)** Suggest how selective breeding could be used to breed cats with fewer Fd proteins in their fur. [3 marks]

---

---

---

---

---

---

---

---

---

---

**(b)** Suggest why it would be an advantage to own a cat with fewer Fd proteins in its fur. [1 mark]

---

---

**(c)** Suggest **one other** desirable characteristic which could be developed in cats by selective breeding. [1 mark]

---

---

**Blank Page**

**8** Human insulin is used to treat diabetes.

Human insulin can now be produced by genetic engineering.

Before human insulin was produced by genetic engineering, insulin was obtained from animals.

**(a)** Explain what is meant by the term genetic engineering. [2 marks]

---

---

---

---





(c) The genetically engineered bacteria are cultured in a fermenter and produce human insulin. The human insulin is then extracted and purified.

(i) Suggest why it is important to purify the human insulin before it is used to treat diabetes. [1 mark]

---

---

Human insulin produced by genetic engineering is more effective than insulin obtained from animals.

(ii) Suggest **two other** advantages of producing human insulin by genetic engineering. [2 marks]

1. \_\_\_\_\_

---

2. \_\_\_\_\_

---

**Blank Page**

**(Questions continue overleaf)**

9 Haemophilia is a genetic condition caused by a recessive, sex-linked allele.

(a) Explain why the allele for haemophilia is described as sex-linked. [1 mark]

---

---

The diagram shows the inheritance of haemophilia in a family.

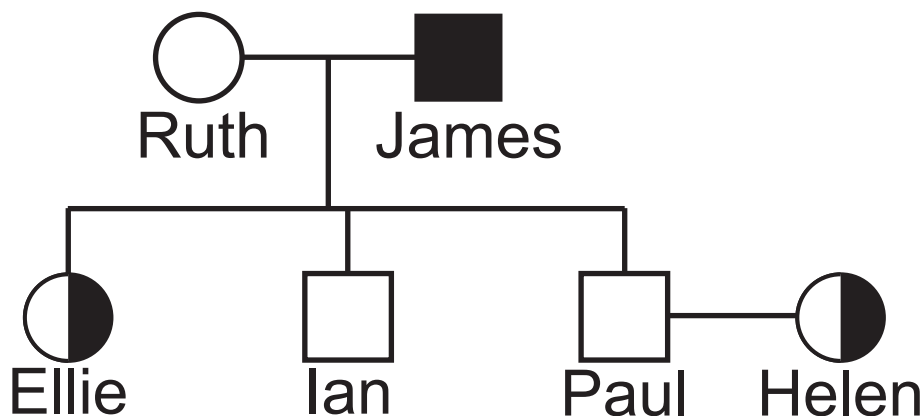

**Key**

○ normal female

□ normal male

◐ carrier female

■ haemophiliac male

**(b)** Name this type of diagram shown on the opposite page. [1 mark]

---

Ellie is a carrier.

**(c)** Describe her phenotype. [1 mark]

---

**(d)** Let  $X^H$  represent a normal X chromosome.

Let  $X^h$  represent an X chromosome carrying the allele which causes haemophilia.

Let  $Y$  represent a Y chromosome.

**(i)** Explain why Ian is a normal male even though his father has haemophilia. [2 marks]

---

---

---

---

Look at the diagram on page 34.

Helen and Paul are expecting their first child.

- (ii) Complete the genetic diagram to show Helen's gametes, Paul's gametes and the possible genotypes of their children. [4 marks]

	<b>Helen's gametes</b>	
<b>Paul's gametes</b>		
	Y	

- (e) (i) What is the percentage probability of Helen and Paul having a child with haemophilia? [1 mark]

\_\_\_\_\_ %

Genetic screening involves testing an individual for the presence of a genetic condition caused by a particular allele.

**(ii)** Suggest why Helen and Paul may have benefited from genetic screening before deciding to start a family.

Use evidence from your completed genetic diagram opposite to support your answer. [3 marks]

---

---

---

---

---

---

---

---

---

---

---

**10 (a)** The diagrams show different types of protein molecule found on the cell membrane of a normal body cell and on a cancer cell from a patient.

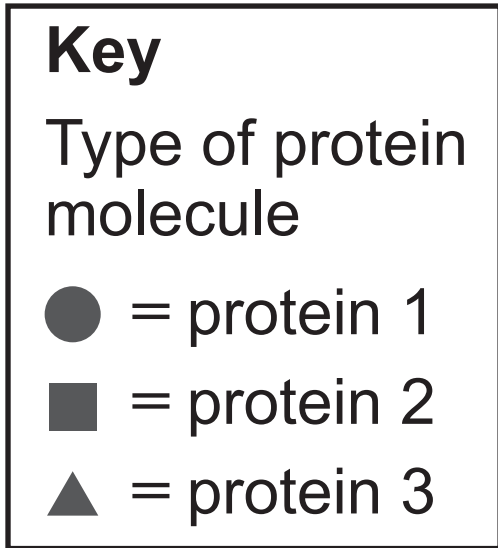

**Normal body cell**

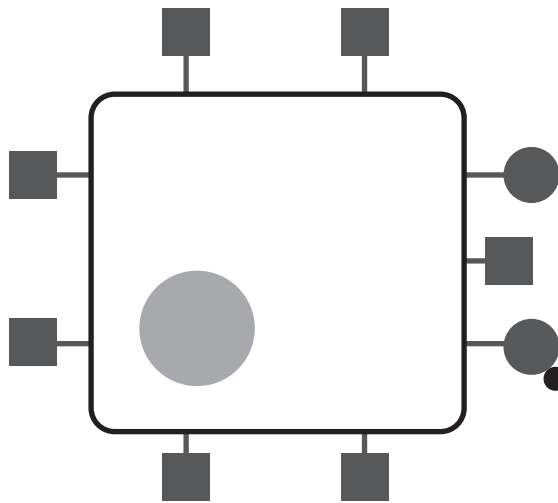

**Cancer cell**

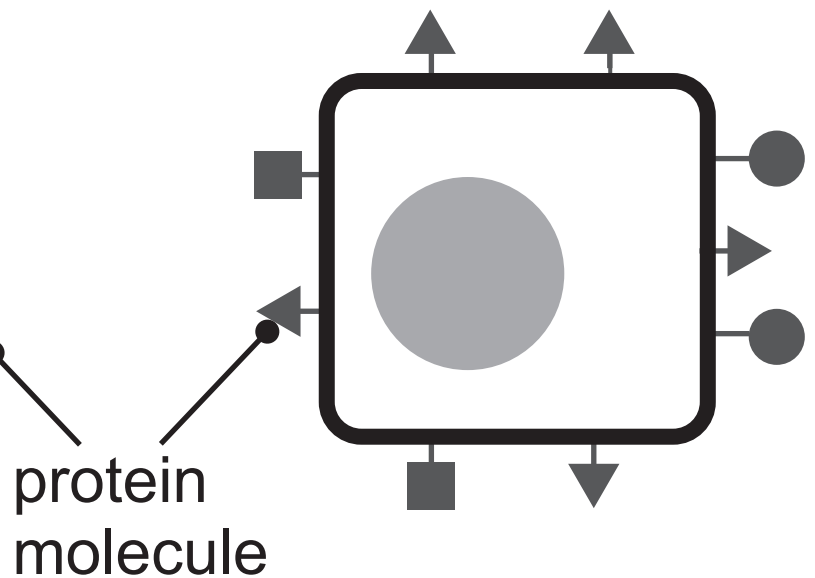

Scientists decided to use antibodies to treat this cancer patient.

Antibodies are used to target specific proteins on the cancer cell.

- (i) Name this type of cancer treatment.  
[1 mark]

---

- (ii) Use the diagram opposite to suggest which type of protein molecule the scientists should target. [2 marks]

Explain your choice.

Protein \_\_\_\_\_

Explanation \_\_\_\_\_

---

---

(iii) Give **one** advantage of this type of treatment compared to other types of cancer treatment. [1 mark]

---

---

(iv) Give **two other** differences between the cancer cell and the normal body cell. [2 marks]

1. \_\_\_\_\_

2. \_\_\_\_\_

---

**Blank Page**

**(Questions continue overleaf)**

**(b)** The scientists carried out the following steps to produce antibodies in the laboratory.

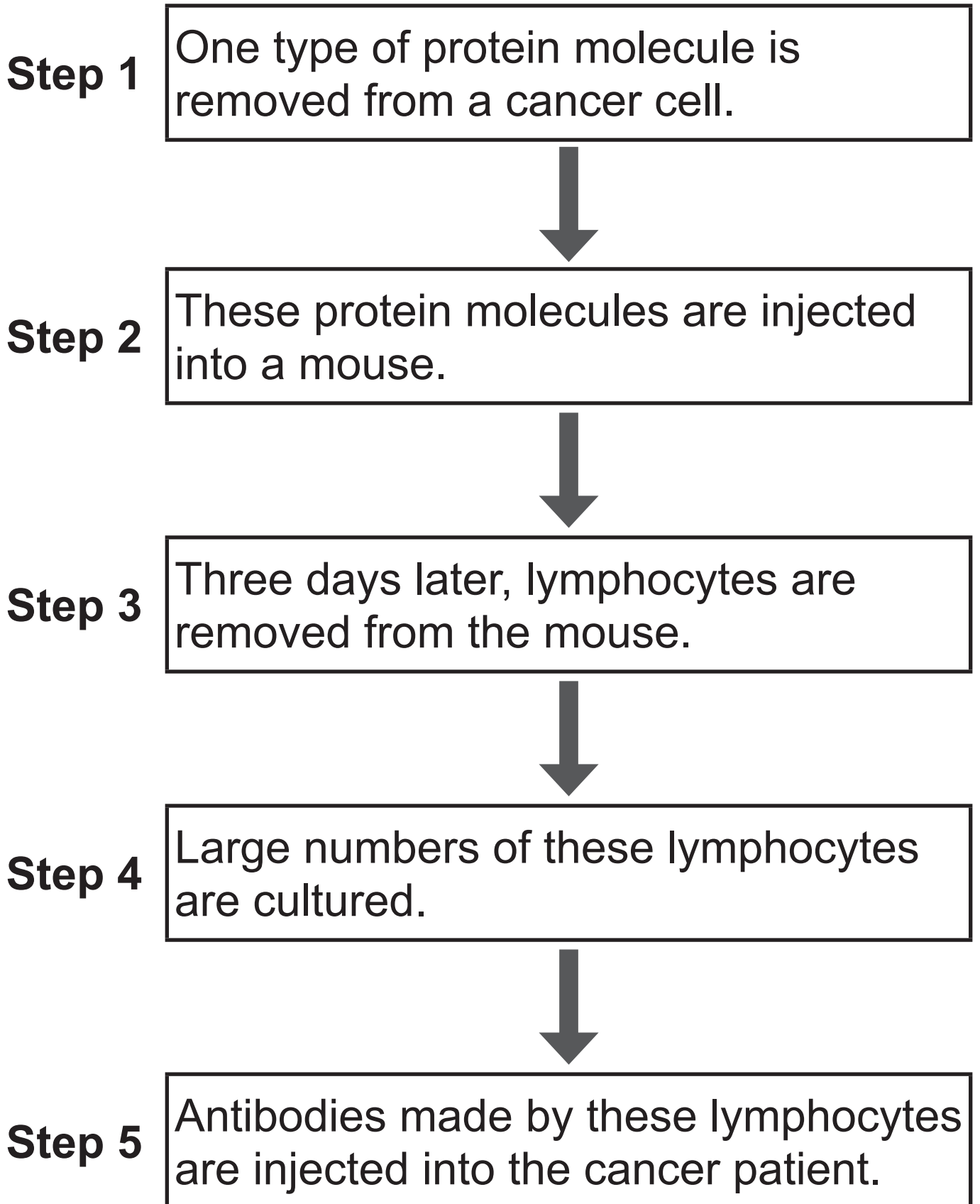

(i) Describe how the lymphocytes in the mouse's body respond to the protein molecule being injected in **step 2**.

[1 mark]

---

---

---

(ii) Suggest why large numbers of lymphocytes are cultured in **step 4**.

[1 mark]

---

---

(iii) Explain what happens to the cancer cells when the antibodies are injected into the patient in **step 5**.

[3 marks]

---

---

---

---

---

---

---

## SOURCES

- Q1(a) . . . © *Principal Examiner*  
Q2(a) . . . © *Principal Examiner*  
Q2(b) . . . © *adapted from Getty Images*  
Q3(a) . . . © *Chief Examiner*  
Q3(b) . . . © *Mikkel Juul Jensen / Science Photo Library*  
Q4(a) . . . © *Getty Images*  
Q4(b) . . . © *Getty Images*  
Q5 . . . . . © *Chief Examiner*  
Q6(b) . . . *www.worldometers.info/coronavirus/country/uk* Data © *Crown copyright*  
Q7 . . . . . © *Principal Examiner*  
Q10(a) . . . © *Principal Examiner*

---

**This is the end of the  
question paper**

---

For Examiner's use only	
Question Number	Marks
1	
2	
3	
4	
5	
6	
7	
8	
9	
10	
<b>Total Marks</b>	

Examiner Number

Permission to reproduce all copyright material has been applied for.  
In some cases, efforts to contact copyright holders may have been unsuccessful and CCEA will be happy to rectify any omissions of acknowledgement in future if notified.